

HAC-UAN433 Series
Ultra Low Power Data Radio Module
Version 2.2C



SHENZHEN HAC TELECOM TECHNOLOGY CO., LTD

Address : Fl.6, Building 2, Jiuxiangling New Industry Park, No.4227, Xilihu Road, Nanshan, Shenzhen, China.

Tel : +86-755-23981078

Fax : +86-755-23981007

E-mail : webmaster@rf-module-china.com

Website : <http://www.rf-module-china.com>



Catalogue

I. Features of HAC-UAN433 Series.....	3
II. Applications of HAC-UAN433 Series.....	4
III. The explanation of type name.....	4
IV. How to use HAC-UAN433 Series.....	5
V. Networking Application of HAC-UAN433 Series.....	14
VI. Technical specification of HAC-UAN433 Series.....	14
VII. Standard configuration of HAC-UAN433 Series.....	15



I. Features of HAC-UAN433 Series

1. Ultra low power transmission with 100mW (20dbm) as maximal transmission power, users can customize 50mW (17dbm).
2. ISM frequency band, requiring no any frequency.
The carrier frequency covers from 427MHz to 437MHz.
3. The real narrowband and high-speed technology.
The bandwidth for signal is 12.5KHz or 25KHz. It is high efficient use for spectrum and high anti-interference. The maximum effective baud rate is up to 9600bps.
4. High anti-interference and Low BER (Bit error Rate)
Based on the GFSK or RC2FSK modulation, the high-efficiency forward error correction channel encoding technology is used to enhance data's resistance to both transient interference and random interference, and the actual bit error rate of $10^{-5} \sim 10^{-6}$ can be achieved when channel bit error rate is 10^{-3} .
5. High sensitivity
When the baud rate is 1200bps, the highest sensitivity can reach -122dBm. When the baud rate is 9600bps, the sensitivity can reach -117dBm.
6. Long Transmission Distance
Within the visible range, when the height of antenna is higher than 2m, and the baud rate is 1200bps, the longest reliable transmission distance is 2000m. But if the baud rate is 9600bps, the reliable transmission distance is 1000m.
7. Transparent data transmission
Transparent data interface used in transceivers is for meeting many standard or nonstandard user protocols.
8. Multi-channels
HAC-UAN433 can offer 32 channels.
9. Two serial ports with three connection methods
HAC-UAN433 offers two serial ports with three connection ports: COM1 is a UART interface of TTL level, and the COM2 can be customized as RS-232 or RS485 by users' software.
10. Big data buffer area
With optional interface baud rate: 1200/2400/4800/9600bps and 8N1/8E1 data format (set by user), the transceiver can transmit no more than 600Bytes data, and the users can



program more neatly.

11. Intelligent data control and no any complicated transmission programs required

Even for half duplex communication, no any excessive programs about RF is required. It is just like the manipulation of RS485 interface.

12. High reliability, small and light

By using monolithic radio-frequency integrated circuit and single-chip MCU, the transceivers have little peripheral circuits, high reliability, and low failure rate.

II. Applications of HAC-UAN433 Series

Auto Meter Reading system

Remote control and monitoring

Automatic data collection system

Wireless monitoring and control for building equipment

Wireless handheld terminal, portable equipment

Control of traffic signal and street lamp

III. The explanation of type name

The type naming method for HAC-UAN433 is as follow:

‘HAC’ - the title of manufacturer: Shenzhen HAC Telecom Technology Co., Ltd

‘U’ - Ultra power, the transmission power is no more than 20dBm

‘A’ - The name of products series

‘N’ - The narrowband products

‘433’ – The center working frequency band,

‘X’ – The type name of this series: X=S standard type.

X=P the module with sleep function

For example: HAC-UAN433P is a module with sleep function.

In the HAC-UAN433 Series, there are some types with different functions. They are shown in Table 1.

Table 1

Type	Baud rate (bps)	Sleep Function	UART	RS-232	RS-485	Method for setting channels

UAN433S	1200-9600	No	Yes	Yes	Yes	Standard methods
UAN433P	1200-9600	Yes	Yes	Yes	Yes	It must be setup under the sleep mode.

Note: The setup method of channel for UAN433P is different from other types. It needs to send more 3 Bytes to active the MCU. Please pay attention to the using method.

IV. How to use HAC-UAN433 Series

HAC-UAN433 offers three interface methods which include RS-232, RS-485 and UART/TTL level interface. It can connect with PC, RS232/RS485 devices, MCU or intelligent equipment directly. The using method is as follow:

1.Power supply

The voltage range of power supply is +4.75~5.25 V DC. Please use better ripple factor. If HAC-UAN433 needs to share power supply and ground with other equipment, please use single point access method. If possible, the signal is insulated by optocoupler, the power supply is insulated by transformer, so that it can get the best communication results, and it is steady and reliable.

When the power supply is 3.3V, the output power will be 50mW, and the corresponding optional output power is 20mW.

2.The definition of connector

HAC-UAN433 offers one 9-pin connector (JP1). Their definitions and connection methods with terminals are shown in Table 2.

Table 2: Pin Definitions and connection methods

Pin	Definition	Instruction	Level	Input / Output	Remarks
1	GND	Power ground		Power ground	
2	VCC	Power supply DC	4.75~5.25V	Input	
3	Rx	The receiver of UART	TTL	Input	COM1
4	Tx	The transmitter end of UART	TTL	output	
5	SGND	Signal ground			

6	A(TxD)	A/TxD		Input / output	COM2
7	B(RxD)	B/RxD		Input / output	Note 1
8	SLP/SET	Sleep / Setup	TTL	Input	Note 2
9	RESET	Reset signal	TTL	Input	Note 3

Note 1: The pin for UAN433S and UAN433H only enable the setup of channels. But the pin for UAN433P enables not only the sleep function but also the setup function. Please pay attention to the using methods.

Note 2: The reset negative pulse must be more than 10 μ S.

3. The connection schematic diagram of HAC-UAN433 transceivers with terminal

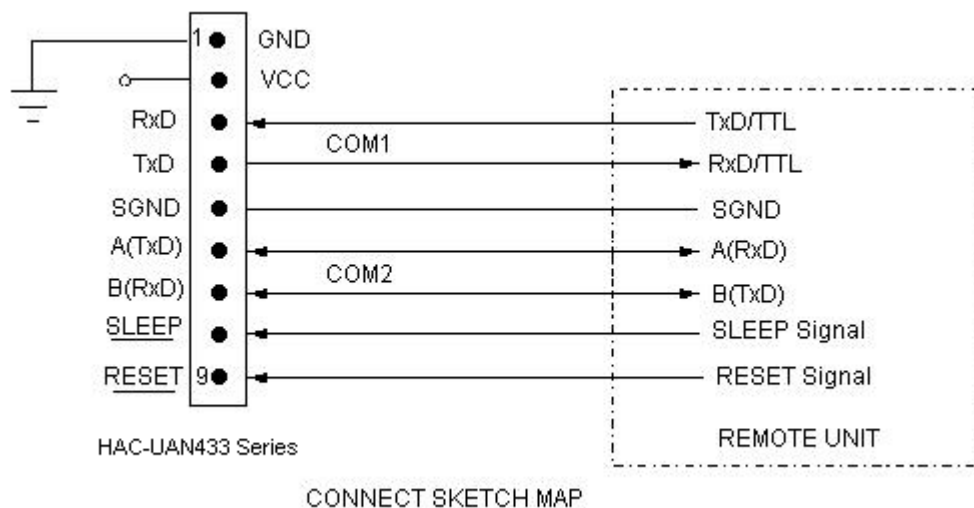

4. Setting the baud rate, interface and data format

Before using the module, you need to make some simple configurations to confirm the channel, interface mode, baud rate, data format and so on according to your needs.

There is a group of 5-bit short-circuit jumper wire (JP2), defined as ABCDE respectively. Define the open circuit of jumper wire (without short circuiter) is mode 1 and short circuit of jumper wire (with short circuiter) is mode 0, then the configuration is shown as Table 3.

Table 3: The definition of jumper wire

NO.	Name	Function	Remarks
A	PW_S	Selection of the Power	5V power supply:A=0: 50mW; A=1: 100mW 3.3V power supply:A=0: 20mW; A=1: 50mW
B	SP_S	Setting baud rate	CB=00: 1200bps; CB=01: 2400bps;
C			CB=10: 4800bps; CB=11: 9600bps



D	COM2S	COM2 Selection	D=0, COM2 is RS-232 interface; D=1, COM2 is RS-485 interface.
E	F_S	8n1/8e1 Selection	E=0: 8n1; E=1: 8e1

Note 1: The air baud rate is equal to the interface baud rate.

Note 2: The BCD pins of UAN433H have no definition. When you use the module, please let the three pins be unconnected.

Note 3: Any changes of the Jumper group will be effective after the module has been power on or reset.

5. Channel configuration for HAC-UAN433S and UAN433H

HAC-UAN433 offers 32 channels. User can use command to set the channel. But different types have different setting methods. And the setting methods for UAN433S and UAN433H are shown as follow:

Let the JP1's 8th pin connect with the ground, and the module will enter into the setting state. The setting command is fixed for 2 Bytes. The first Byte is command word, and the other Byte is parameter (channel No), the format is shown as follow: Comm, Para.

Comm is command word. There are 2 command words for setting channel:

When Comm = 'C' (0x43), it means it will setup the channel and save the channel No in the EEPROM. When the module starts next time, it will use the channel No in the EEPROM as the initialization. Because the command needs to be written in the EEPROM, the executing time is long, it needs about 10ms.

When Comm = 'c' (0x63), it means it will setup the channel and not save the channel number. When the module starts next time, it will use the channel No in the EEPROM as the initialization. The execution for this command is very quick, it just needs about 1ms.

Para is channel parameter, its value is from 0x00 to 0x1F.

After setting the channel successfully, the module will return one Byte currently channel No, it is a hexadecimal number that its value is between 0 and 31.

UAN433S can setup the channels through the COM1 and COM2 port.

UAN433H can only setup the channels through the COM1 port (UART/TTL).

6. Channel configuration for HAC-UAN433P

The setting method for HAC-UAN433P is different. It must be setup under the sleep mode.

The setting method is shown as follow:

Let the JP1's 8th pin (SLP/SET) connect with high level or hang in the air, and the module will enter the sleep state. But before setting the channel, you need to active the MCU. The method for activation is sending 3 Bytes 0xFE before the command, i.e. 0xFE, 0xFE, 0xFE, Comm, Para. 0xFE, 0xFE, 0xFE are characters for activation and synchronization. There is not any delay between 0xFE and Comm. The command definition and return are the same as the UAN433S. After the module returns the channel No, the module will enter into the sleep state again.

UAN433P can setup the channels through COM1 and COM2 port.

7. Channel frequency

Table 4: Channel frequency

Channel NO	Frequency	Channel NO	Frequency	Channel NO	Frequency	Channel NO	Frequency
0	427.000	8	429.400	16	431.800	24	434.200
1	427.300	9	429.700	17	432.100	25	434.500
2	427.600	10	430.000	18	432.400	26	434.800
3	427.900	11	430.300	19	432.700	27	435.100
4	428.200	12	430.600	20	433.000	28	435.400
5	428.500	13	430.900	21	433.300	29	435.700
6	428.800	14	431.200	22	433.600	30	436.000
7	429.100	15	431.500	23	433.900	31	436.300

Note: The default channel of ex-factory is the 31st channel, the corresponding frequency is 436.300MHz.

8. The control for the low consumption

UAN433P is a module with sleep function. The sleep and working mode are controlled by the SLP (JP1/Pin8) signal. When SLP is equal to 0, the module will enter into the working mode, when SLP is equal to 1, the module will enter into the sleep mode. But if you use the module with sleep function, please pay attention to the questions that are shown as follow:

a. The priority of sleep control is lower than the transmitting or receiving in the air, i.e. when the SLP signal is in the high level, if the module is in the transmitting state, it will transmit all the data in the transmitting buffer continually, and then enter into the sleep

mode. When the SLP signal is in the high level, you'd better not transmit the data to the module through serial port. If the module is receiving a legal data package from the air, the module will finish the receiving and send out the data through serial port, and then enter into the sleep mode.

b. When the module enters into the sleep mode, the level of the connection signal for RF module should keep consistent with the external equipment.

c. In the sleep mode, you'd better not use RS232 interface, i.e. the 6th and 7th pin of JP1.

d. The timing diagram for sleep function

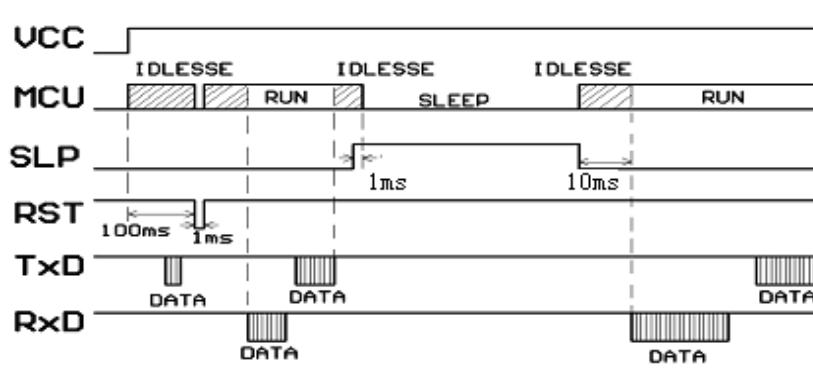

About the module without sleep function, users can cut off the power supply through electron switch to satisfy the power-saving purpose. When you use this method, pay attention to the connection signal level that connects with the external equipment and the time order relation, make the module achieve the minimum current consumption and ensure that the MCU isn't in the working state. The details are shown as follow:

a. Before cutting off the power supply, when the module outputs signal to external equipment, the external equipment must have high impedance input.

b. Before cutting off the power supply, when external equipment inputs signal to the module, external equipment must output the low level to the module.

In a word, before cutting off the power supply, please ensure that any signal wire connect with the external equipment should be low level. Or it will not only consume the current but also bring the illegal working of the MCU and cause some irreversible consequences. For example modify the EEPROM data illegally. Because after the MCU has been cut off the power supply, if there is still some voltage fed to one certain IO port, it will be the creepage power of the MCU, it will cause the illegal working of the MCU, make the MCU

work abnormally (because the current is not big enough) and modify the data or bring some unpredictable consequences.

9. The attentions for data transmission

9.1 The delay time (t_c) of conversion between transmitting and receiving is less than 1ms.

Timing diagram:

HAC-UAN

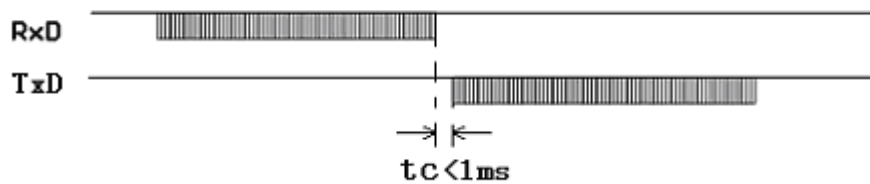

9.2 The delay time of transceivers between the first byte sent by Tx D and the first byte received by Rx D.

Due to the data processing will be made on user's data by HAC-UAN transceiver using FEC (Forward Error Correction) or other correction algorithm, when Rx D of HAC-UAN transceiver 'A' receives the data, then transmits it, the other one transceiver 'B' will have a delay (t_s) to receive and transmit by Tx D. Different RF data rate causes different delay time. Please see the specific delay time below:

RF baud rate (bps)	Delay t_s (ms)	RF baud rate (bps)	Delay t_s (ms)
1200	120	9600	15
2400	60	19200	8
4800	30		

Timing diagram:

HAC-UAN



9.3 Error dealing procedure

To enhance the reliability and stability of user's systems, a verify bit or a Cyclic Redundancy Check (CRC) mode is highly recommended to resent the wrong information

while using HAC-UAN series modules.

9.4 Large-number data transmission

In theory, when the interface data rate is faster than the RF data rate, HAC-UAN transceivers can send unlimited-long data package, but any long packages more than 120B are not recommended. The length of each package should be between 60~100B. We also recommend user to resent the wrong information using Automatic Error Request Equipment (ARQ).

The analyzing as below:

What if the actual transmission BER (Bit Error Rate) is 10^{-4} , 1 packet with 1KB data, which is about 10-thousand bits, is sent, theoretically, at least 1 bit will be received wrongly, then the 1KB information will never be received correctly.

But if we package the data into 10 packets with 100B for each, when all 10 packets are sent, there will be only 1 packet wrong according to this probability. After that, resend this wrong packet using ARQ mode. So by resending one more packet and the efficiency rate is reduced 10%, but all data will be absolutely received correctly.

10. Antenna configuration:

Many appropriate antennas for HAC-UAN433 are selected for meeting different user antenna configurations. The main options of antennas are external helical antenna with SMA joint, microstrip antenna and spring antenna. If users need the special antenna, we can customize the other spec antennas or add the PCB antenna in the design of the module.

10.1 Antenna with SMA joint:

- a. HAC-LX433-10-SMA: 80mm helical SMA antenna with straight joint, low cost.



- b. HAC-LX433-3-SMA: 35mm SMA antenna, inner magnetic material, high gain, small size, beautiful appearance (like the mobile phone antenna).



c. HAC-LX433-10-ZSMA: 100mm SMA antenna with folding joint, rubber helical antenna, convenient to installation.



d. HAC-XP433S-100H-SMA: little magnetic antenna with 100cm antenna feeder, high gain, convenient to installation.



10.2 Microstrip antenna, HAC-WD433-3



10.3 spring antenna



Our products can be embedded in users' equipment, if it doesn't have enough space to put the module, users can use the module with the spring antenna.

11. Indicator light

There is one red LED indicator light. When the module powers up or resets, the LED light

will flicker, it means that the module has been connected with the power supply. About the UAN433P, when it is in the sleep mode, the LED light is dark, when it is in the activation mode, the LED light is bright. About the other types, using SET (JP1/ Pin8) pin to setup, the LED light is bright, and in the other time, the LED light is dark.

12. Dimension sketch map (Unit: mm):

The dimension of our standard product is shown as follow. To meeting different need of users, smaller sizes and different shapes can also be provided.

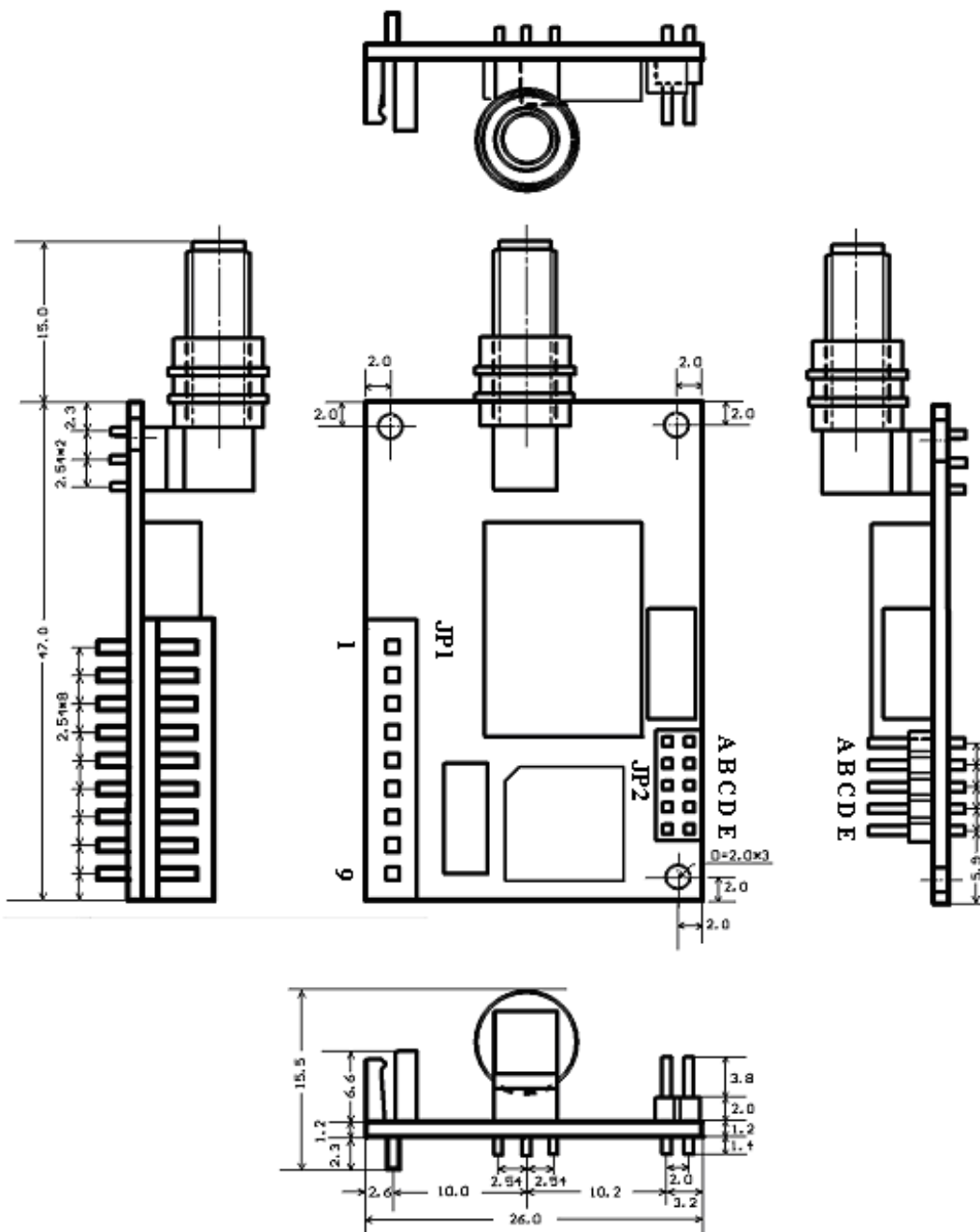

V. Networking Application of HAC-UAN433 Series

The communication channel of HAC-UAN433 is half duplex, which is mostly suitable for the communication mode of point to multi-point. Under this mode, one master station must be set, and all of the rest are slave stations with a unique address. The coordination of communication is controlled by master station that uses data frames containing address code to transmit data or command. All of slave stations will receive the data and command and compare the received address code with local address code. If they are different, the data will be dismissed with no response. If they are same, it means the data is sent to the local. Slave station will make different responses according to the transmitted data or command and send the data back as response. All these jobs must be performed by upper level protocol, which will assure that there is only one transmitter-receiver in transmission mode in the communication network at any transient moment so as to avoid the cross-interference.

HAC-UAN433 transceivers can also be used for point-to-point communication with easier operation. For the programming of serial port, all you have to do is to remember that its communication mode is half duplex and always to observe the time sequence of come-and-go for receiving and transmitting.

VI. Technical specification of HAC-UAN433 Series

Modulation mode	: GFSK/RC2FSK
Working frequency	: 427~ 437MHz
Transmission power	: 17/20dBm (optional)
Receiving sensitivity	: -122dBm @ 1200bps (1% BER)
Channel bandwidth	: ≤ 25 KHz
Frequency stability	: ± 2.5 ppm
Channel interval	: 300KHz
Channel	: 32
RF data rate	: 1200/2400/4800/9600bps(optional)
Interface data format	: 8E1/8N1 (optional)
Temperature	: -40°C~80°C (Industry)
Power supply	: +4.75 ~ 5.25VDC (The maximum output power is 100mw) +3.3V (The maximum output power is 50mw)

